



Engine	Cummins QSL9.3
Gross Power	180 kW (241 hp / 245 ps) @ 2,200 rpm
Net Power	162 kW (217 hp / 220 ps) @ 2,200 rpm
Operating Weight	19,958 kg
Standard Bucket Size	4.0 m ³
Max Breakout Force	174 kN
Standard Dump Clearance	2,983 mm

862H WHEEL LOADER

862H SPECIFICATIONS >>>

ENGINE

Emission Regulation	Tier 3 / Stage III
Manufacturer	Cummins
Model	QSL9.3
Gross Power	180 kW (241 hp / 245 ps) @ 2,200 rpm
Net Power	162 kW (217 hp / 220 ps) @ 2,200 rpm
Peak Torque	1,187 N·m
Displacement	9.3 L
Number of Cylinder	6
Aspiration	Turbocharged & Air-to-air intercooled

TRANSMISSION

Transmission Type	Countershaft, power shift
Torque Converter	Single stage, three elements
Maximum Travel Speed, fwd	37 km/h
Maximum Travel Speed, rev	26 /h
Number of Speed, fwd	4
Number of Speed, Rev	3

AXLES

Differential Front Type	Conventional
Differential Rear Type	Conventional
Axle Oscillation	±12°

STEERING

Steering Configuration	Articulated
Steering Relief Pressure	19 MPa

BRAKES

Service Brake Type	Caliper discs brake
Service Brake Actuation	Air over hydraulic
Parking Brake Type	Manual air control
Parking Brake Actuation	Menchanical

HYDRAULIC SYSTEM

Main Pump Type	Gear
Main Relief Pressure	20.7 MPa
Raise	5.7 s
Dump Time	1.3 s
Float Down Time	3 s
Fastest Total Cycle Time	10 s

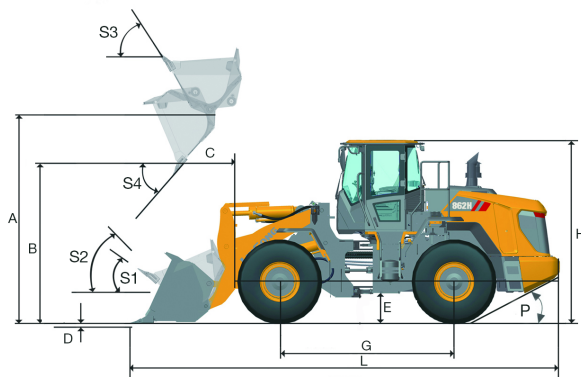

LOADER ARM PERFORMANCE with Standard Bucket 4.0 m³

Tipping Load - Straight (ISO 14397-1:2007)	16,142 kg
Tipping Load - Full Turn (ISO 14397-1:2007)	13,642 kg
Maximum Bucket Breakout Force	174 kN
A Maximum Hinge Pin Height	4,212 mm
B Dump Clearance at Full Height Discharge	2,983 mm
C Dump Reach at Full Height Discharge	1,312 mm
D Maximum Digging Depth, Bucket Level	80 mm
S ₁ Rollback at Ground Level	43°
S ₂ Bucket Rollback at Carry	48°
S ₃ Bucket Rollback at Maximum Height	63°
S ₄ Maximum Dump Angle at Full Height	45°

BUCKET PERFORMANCE

Reference Bucket	3.0-6.5 m ³
------------------	------------------------

DIMENSIONS

E Ground Clearance	431 mm
G Wheelbase	3,450 mm
H Cab Height	3,467 mm
J Wheel Tread	2,280 mm
K Width Over Tires	2,880 mm
L Length with Bucket Down	8,793 mm
M Turn Angle, Either Side	38°
P Rear Angle of Departure	27°
R ₁ Turning Radius, Bucket Carry	7,253 mm
R ₂ Turning Radius, Outside of Tire	6,450 mm
W Width Over Bucket	3,232 mm

TIRES

Tire Size	23.5 - 25
-----------	-----------

OPERATING WEIGHTS

Operating Weight	19,958 kg
------------------	-----------

SERVICE CAPACITY

Fuel Tank	330 L
Engine Oil	22 L
Cooling System	52 L
Hydraulic System	280 L
Transmission and Torque Converter	35 L
Axles, Each	41 L

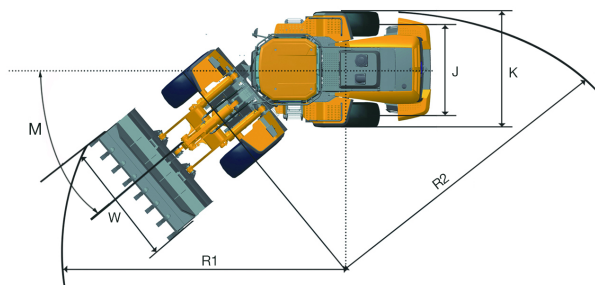

Guangxi Liugong Machinery Co., Ltd.

No. 1 Liutai Road, Liuzhou, Guangxi 545007, PR China
T: +86 772 3886124 E: overseas@liugong.com
www.liugong.com

Specifications and designs are subject to change without notice. Machines shown may include optional equipment. Liugong standard and optional equipment may vary from region to region. Please consult your Liugong dealer for information specific to your area. Engine power kW is converted to horsepower (1 kW=1.3596 ps and 1 kW=1.3410 hp) in this file.

04/2020 Designed by LiuGong
Replace the previous versions of 12/2019