

Engine	Cummins 6LTAA9.3
Gross Power	162 kW (220 hp) @ 2,200 rpm
Net Power	154 kW (209 hp) @ 2,200 rpm
Operating Weight	17,000 kg
Standard Bucket Size	3 m <sup>3</sup>
Standard Breakout Force	172 kN
Standard Dump Clearance	3,100 mm

# 856H

WHEEL LOADER



TOUGH WORLD. TOUGH EQUIPMENT.

# 856H SPECIFICATIONS >>>

## ENGINE

Emission Regulation	Tier 2 / Stage II
Make	Cummins
Model	6LTAA9.3
Gross Power	162 kW (220 hp) @ 2,200 rpm
Net Power	154 kW (209 hp) @ 2,200 rpm
Peak Torque	940 N · m
Displacement	9.3 L
Number of Cylinder	6
Aspiration	Turbocharged & Air-to-air intercooled

## TRANSMISSION

Transmission Type	Countershaft, power shift
Torque Converter	Single stage, three elements
Maximum Travel Speed, fwd	40 km/h
Maximum Travel Speed, rev	25 km/h
Number of Speed, fwd	4
Number of Speed, Rev	3

## AXLES

Differential Front Type	Limited slip
Differential Rear Type	Limited slip
Axle Oscillation	±12°

## STEERING

Steering Configuration	Articulated
Steering Relief Pressure	18 MPa

## BRAKES

Service Brake Type	Wet discs brake
Service Brake Actuation	Hydraulic
Parking Brake Type	Manual electronic control
Parking Brake Actuation	Hydraulic

## HYDRAULIC SYSTEM

Main Pump Type	Gear
Main Relief Pressure	20.7 MPa
Raise	5.7 s
Dump Time	1.3 s
Float Down Time	3 s
Fastest Total Cycle Time	10 s

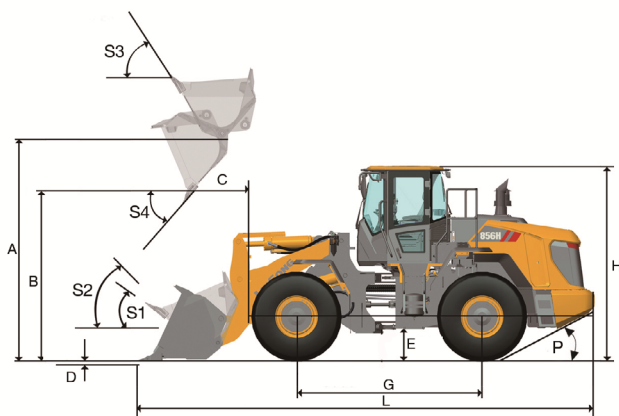

## LOADER ARM PERFORMANCE

Tipping Load - Straight	12,400 kg
Tipping Load - Full Turn	10,800 kg
Bucket Breakout Force	172 kN
A Maximum Hinge Pin Height	4,150 mm
B Dump Clearance at Full Height Discharge	3,100 mm
C Dump Reach at Full Height Discharge	1,050 mm
D Maximum Digging Depth, Bucket Level	35 mm
S <sub>1</sub> Bucket Rollback at Ground Level	42°
S <sub>2</sub> Bucket Rollback at Carry	48°
S <sub>3</sub> Bucket Rollback at Maximum Height	58°
S <sub>4</sub> Maximum Dump Angle at Full Height	45°

## BUCKET PERFORMANCE

Reference Bucket	2.6 - 5.6 m <sup>3</sup>
------------------	--------------------------

## DIMENSIONS

E Ground Clearance	431 mm
G Wheelbase	3,320 mm
H Cab Height	3,450 mm
J Wheel Tread	2,150 mm
K Width Over Tires	2,750 mm
L Length with Bucket Down	8,253 mm
M Turn Angle, Either Side	38°
P Rear Angle of Departure	27°
R <sub>1</sub> Turning Radius, Bucket Carry	6,914 mm
R <sub>2</sub> Turning Radius, Outside of Tire	6,205 mm

## TIRES

Tire Size	23.5 - 25
-----------	-----------

## OPERATING WEIGHTS

Operating Weight	17,000 kg
------------------	-----------

## SERVICE CAPACITY

Fuel Tank	300 L
Engine Oil	20 L
Cooling System	52 L
Hydraulic System	236 L
Transmission and Torque Converter	35 L
Axles, Each	44 L

